

TE10

Vibratory Feeding Net Weigh Scale

Taylor Products' TE10 is an electronic, small net weigh scale designed for weightments of 2 oz to 5 lb. The TE10 was designed with a timed discharge to eliminate spillage, as well as controls for single operator convenience.

Variable Speed Electronic Scale for Small Accurate Weights

- 2 oz to 5 lb capacity*
- Granulars
- Powders
- Up to 20 weightments per minute



*Weight range is dependent on product's bulk density. Free product testing recommended.



A leader in the design and manufacture of packaging automation systems and equipment. Established 1969.

Specifications TE10



Diagram dimensions are for reference only

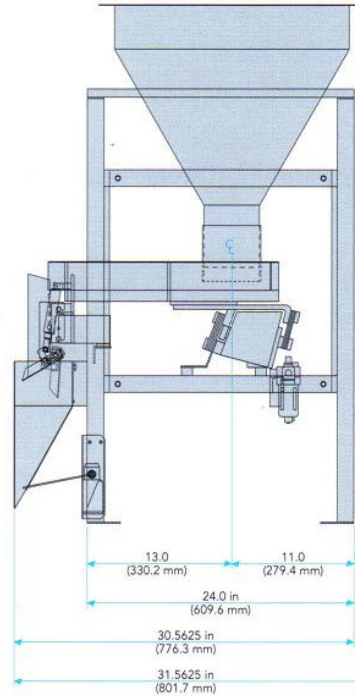
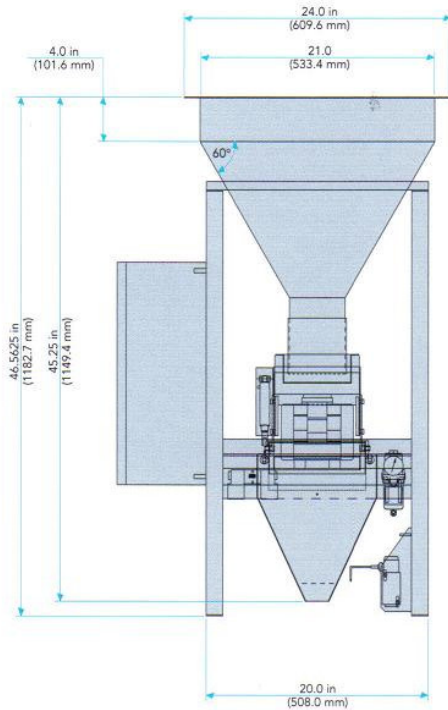

Dimensions	24 in (609.6 mm) x 31.5625 in (901.7 mm) x 46.5625 in (1,182.7 mm)
Speed	Up to 20 WPM
Accuracy	Up to 0.4%
Weight Range	2 oz to 5 lb (0.057 kg to 2.268 kg) Weight range is dependent on product's bulk density. Free product testing recommended.
Scale	Analog Touchpad
Construction	11 Gauge, 1.5 in x 1.5 in 304 S/S Tubular Support Frame, 304 S/S Contact Points, Table Top Mount, Conical Hopper Design
Electrical Requirements	120 Volt, 5 amp
Compressed Air	90 PSI / 1 CFM
Standard Features	Adjustable Flow Boot, Dual Set-Point, Bulk Accumulation Feature for weights over 5 lbs, Tool-less Disassembly for Clean-up, Auto-Zero



©2005 Magnum Systems, Inc. All rights reserved. Catalog number: MS.1011.0805



www.magnumsystems.com

Toll Free 888.882.9567 Phone 620.421.5550 Fax 620.421.5531
2205 Jothi Avenue, Parsons, Kansas 67357-8460